



EMP Basic

User Manual

**Dear FagronLab™ user, dear Compounder
thank you for choosing the EMP technology.**

You have purchased a quality system for advanced pharmaceutical compounding.
Please read the following operation manual carefully.
For more information and compounding recommendation consult our homepage

**www.fagronlab.com
www.fagron.com**

For additional support, operation handling and all other questions regarding
the technology please feel free to contact your local Fagron company or dealer.

Enjoy the successful production of quality assured compounding.

Your
FagronLab™
Compounding Support Team

Contents

Quick Start	6
1. Installation information	7
2. Initial operation	7
3. The Unguator technology - Competence from the start	9
3.1 FagronLab™ mixing devices	9
3.2 EMP Basic	10
3.3 EMP Standard	10
3.4 EMP Pro	10
3.5 FagronLab™ assortment	11
4. Display handling	17
4.1 Initial operation	17
4.2 Compounding with the EMP Basic	20
4.4 Aborting the mixing process	21
5. Compounding guidelines for the technology	22
5.1 Preparing the FagronLab™ mixing unit	22
5.2 Weighed portion of the formulation	22
5.3 The mixing process	22
5.4 Mixing parameters	23
5.5 Requirements for the components of a formulation	25
5.6 After the mixing process is complete	26
6. General notes on the FagronLab™ mixing system	27
6.1 Identification number ID	27
6.2 Error codes	28
6.3 Operation errors	28
6.4 Cleaning the EMP Basic	29
7. Service and warranty	30
7.1 Notes on malfunctions	30
7.2 Notes on safety	30
7.3 Technical data of the EMP Pro	30
8. Manufacturing and Customer Service	31
8.1 Installation qualification (IQ)	32
8.2 Operation qualification (OQ)	34

Quick Start

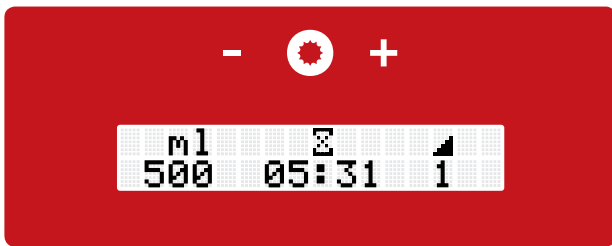
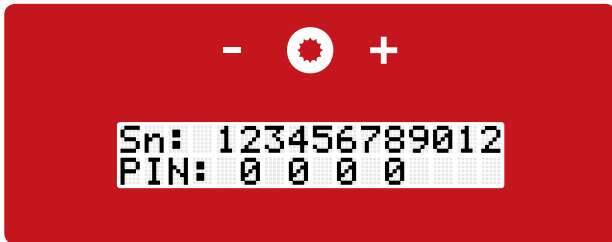

How to register your EMP Basic device

- Go to www.fagronlab.com/re
- Enter the 12 digit serial number
- Enter the four digit unlock PIN on your device

Display handling

- Touch panel with: Minus button (left), Compounding button (middle), Plus button (right)
- Start display shows jar size, mixing time and mixing speed
- After pushing the compounding button for two seconds "Start" appears on the display and the jar can be mounted



Lift arm with integrated quick-lock coupling

- Hold the FagronLab™ logo on top of the jar to the front; insert the mixing shaft directly from the front into the lift arm
- Insert the mixing unit from below
- Fix the jar with a slight turn counterclockwise (about a quarter turn) into the lift arm and push the Compounding button

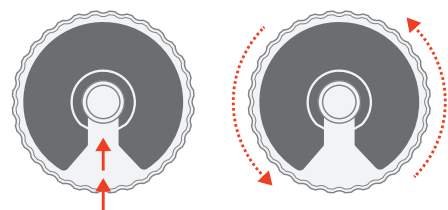

1. Installation information

The EMP Basic weighs 24 lbs (11 kg).

Select a suitable location for the EMP Basic.

- Solid, horizontal surface
- Away from direct airflow from air conditioning systems, heaters, open windows or fans
- No direct sunlight, keep the temperature steady between 15 - 30°C (59 - 86°F) and maximum humidity of 80%
- Clean, dry and dust-free

Remove all components from the cardboard box.

Check to ensure that the following components are included in your shipment:

- 1x EMP Standard mixing device
- Standard mixing Blades 1 - 4
- 1x Power cable
- 1x Disposable Blade starter kit I
- 1x Operating instructions



Note

- Please contact the FagronLab™ support team at your local Fagron or official dealer in case components are missing or arrived damaged.
- To ensure proper return without additional costs please, hold on to the original cardboard box and packing material of the **EMP Standard**.
- The warranty lapses if the original packing materials are not used for return deliveries.

2. Initial operation

- If the device is exposed to cold weather conditions, please allow the device to acclimatize for approx. 30 minutes, this will prevent humidity and condensation from interfering with the device's proper operation.
- The socket outlet is located on the rear of the **EMP Standard**. First connect the power cord to the socket outlet and then plug the power cord into the power outlet.
- The power button is also the emergency button. It is located on the rear of the device.
- Use the power button to turn on the **EMP Standard**. Now the device is ready for operation.

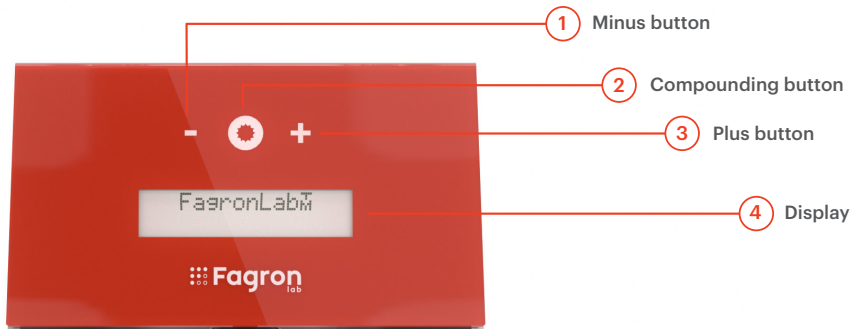

5 Automatic lift arm with quick-lock coupling

Power button/emergency button

1

RS232 port

2

Socket outlet

3

3. The Unguator technology - Competence from the start

The **FagronLab™** product line is based on the Unguator Technology originally patented by Gako Konietzko GmbH, Germany. The core of the technology is to comply with requirements of prescribed semi-solid formulations. It consists of the patented arrangement of the Mixing Blade and the jar that serves as both, a hygienic mixing jar and a hygienic dispensing jar.

The principle of the preparation method using technology in the closed FagronLab™ mixing system is quick and easy to learn, true to the motto:

"learning by doing"

A little experience will make it easy to prepare all semi-solid formulations, though it may seem rather complicated at first. Using the technology enables the pharmacy to better prepare prescription ointments in a shorter period of time, compared to the conventional methods. For the first time, it is possible to not only standardize ointments, but validate them, too.

3.1 FagronLab™ mixing devices

The current FagronLab™ mixing devices - **EMP Basic**, **EMP Standard** and **EMP Pro** - are useful and advanced improvements. The FagronLab™ mixing devices feature a high safety standard. They were audited for safety by TÜV Rheinland, Germany.

The devices are manufactured by Gako International GmbH, Schesslitz - Germany. With increased product quality, product uniformity and reproduction of ointments prepared individually and in batches were vastly improved.

Method of ointment preparation	Pharmaceutical quality	Uniformity of ointment	Lift arm	Mixing parameters (rpm, mixing time)
Mortar and Pestle	●●○○	●○○○	—	Individually
EMP Basic	●●●○	●●●○	Manual guided lift	Individually programmable
EMP Standard	●●●○	●●●○	Automatic	Individually programmable
EMP Pro	●●●●	●●●●	Automatic	Fully automatic

Tab: Quality improvements with increasing automation



3.2 EMP Basic

- The **EMP Basic** ensures a GMP suitable preparation of semi-solid compounds up to 500 ml.
- The lift by hand is much easier through the guided lift arm with integrated quick-lock coupling.
- Jar size, mixing time and ten mixing speeds can be set on the **EMP Basic**.

3.3 EMP Standard

- The **EMP Standard** ensures a GMP suitable preparation of semi-solid compounds up to 500 ml
- The integrated quick-lock coupling allows for faster attachment of the mixing unit into the lift mount
- The lift arm works automatically so the mixing time can be used for e. g. documentation
- Jar size, mixing time and ten mixing speeds can be set with the **EMP Standard**.

3.4 EMP Pro

- The **EMP Pro** is the complete solution for the pharmacy
- The **EMP Pro** will not only support GMP compounding of semi-solid preparations up to 2000 ml. It also will be useful for additional compounding needs in the pharmacy
- Another beneficial feature will make stirring in medicine bottles possible
- Integrated standard mixing programs (suspension, emulsion, gel, etc.) with default mixing parameters makes the production of semi-solid compounds a lot easier. It is possible to rescale an already created mixing program to a different jar size to ensure the constant quality of the compound. This feature is time saving because there is no need to recalculating the parameters for an existing mixture. The optimized mechanics and electronics ensure a quiet operation
- In addition, the **EMP Pro** is preloaded with a database of several mixing parameters for semi-solid NRF formulations. This will optimize the manufacturing of NRF and NRF similar formulations and increase the compound quality
- The **EMP Pro** is equipped with several ports and ready for potential interconnection with electronic scales, printers (label, paper), keyboard and networking.



3.5 FagronLab™ assortment

As well as the FagronLab™ devices, the FagronLab™ assortment underlies further and new developments. All FagronLab™ accessories are compatible with all current and former available FagronLab™ mixing devices.

FagronLab™ stirrer

The FagronLab™ stirrer are the FagronLab™ Standard Mixing Blade (SMB) and the FagronLab™ Disposable Blade (Disp. Blade). The stirrers are steadily guided up and down inside the jar. Their unique design results in a tight contact between the mixing blade and the inside wall of the jar, which serves, primarily, for distributing the substances during the mixing process.

The lubrication effect of the ointment and the foundation generally protects the jars and the stirrer against abrasion. Discolorations of the mixing blade are mostly irreversible and therefore harmless. All SMB and Disp. Blade shafts are dishwasher safe.

The SMB and mixing shaft of the disposable blades are coated with titanium nitride, which makes them more resistant towards chemical and physical influences.

Assignment of the FagronLab™ stirrer

Ensure to use the correct stirrer for the corresponding jar. Selecting the wrong shaft may cause failure messages with the automated devices. Also ensure that the right shaft is used when working with the Disp. Blade. Both available shafts are marked for use with sizes 15 - 100 ml or 200 ml in the FagronLab™ jar. They have to be combined with the correct Disp. Blade. While the same Disp. Blade is used for the 100 ml and 200 ml jar sizes, it still needs a different shaft for each. See also the operation instructions that come with the disposable blade shafts.

Flowing recess of the FagronLab™ SMB

The flow-adapted shape of the SMB generally cleans itself during the rotating penetration of the ointment. Depending on ointment's ingredients', compatibility of weighted formulation and also if the jar is considerably under filled (e.g. large volumes of powder), unmixed ingredients may adhere to the SMB in recesses of flow. These remnants should be transferred into the jar using a spatula when about half of the mixing time is complete.

The air should be diminished again, by pushing the bottom of the jar up, following this process. When using the Disp. Blade, however there are no recesses of flow and no remedial work is generally required.

Warming

The warmth that develops from the friction between the stirrer and the inside wall of the jar is generally desired. Decreased viscosity increases the wettability of powders and accelerates the penetration of potential powder pockets. Even the emulsifying ability of fats and oils benefits by warming.

A temperature of 54°C / 129°F was the maximum taken after 6 minutes of mixing a highly pasty preparation made of vaseline and zinc oxide at full speed.

This temperature increase is generally safe for the substances used in the pharmaceutical field. Ointments of low viscosity only heat slightly. Volatile substances such as ethereal oils or alcohol do not evaporate from the closed mixing unit.

Cleaning the FagronLab™ stirrer

The stirrer is normally cleaned with a paper towel and, if necessary, held under hot water faucet and then dried with a paper towel. The stirrers can also be cleaned in the dishwasher.

The FagronLab™ devices as well as the FagronLab™ line of products should never be treated with sharp-edged objects or abrasive cleaning agents.

FagronLab™ Standard Mixing Blade (SMB)

The FagronLab™ SMB's are adjusted to the size of each individual FagronLab™ jar. For jar size 100 ml and 200 ml use the same SMB, also the 300 ml and 500 ml jars share a SMB. Before each use make sure the SMB used has the correct length, and the blades are clean prior using them (e.g. cleaning with isopropanol 70%).

The SMB is suitable for the production of all kinds of formulations. We recommend especially for suspension ointments and pre-grinding the use of the standard mixing blade.



FagronLab™ Disposable Blade



FagronLab™ Disposable Blade Shaft

FagronLab™ Disposable Blade (Disp. Blade)

The FagronLab™ Disp. Blade is suitable for all FagronLab™ devices. The one time use mixing blade is connected to the disp. blade shaft by pushing it down and twisting the blade counterclockwise, it can be disconnected after the mixing process with a clockwise turn.

The material contact in the ointment is three times higher due to the three times amount of blades when using the Disp. Blade compared to the SMB at the same mixing speed. The counter rotating twist of the mixing blades causes intensive material vibration, therefore a better distribution in the material to be mixed and achieves good product quality faster than using the SMB. However, we recommend using the same mixing time as for the SMB.

In the obligated process of final quality control the mixing blade can be removed and discarded or left inside the jar. Cleaning is limited to the Disp. Blade shaft. We also recommend using the Disp. Blade for substances that may discolor the regular blade. This type of stirrer also comes with different shaft lengths. Every shaft is imprinted on its thinner end with the associated range of jar sizes, 15 - 100 ml and 200 ml. Disp. Blades are specially suitable for compounding emulsion, gels and "soft in soft" formulations. For suspension ointments and pre-grinding is recommended the use of SMB.

FagronLab™ jar

The FagronLab™ jar is both, a mixing and a dispensing jar, and is therefore designed as a disposable jar. The jar guarantees evaporation free and contamination free preparation in an air reduced mixing space.

The FagronLab™ jar lid closes the jar tightly to prevent evaporation and therefore loss of active ingredients. Used as a dispensing jar, the jar corresponds to the guidelines for quality assurance from the German Chamber of Pharmacists ("Apothekerkammer"). With its small dispensing opening, comparable to a tube and without an environmental contamination surface, the jar guarantees the minimization of negative quality interference demanded by section 13, ApBetrO (Pharmacy Operation Regulations); including those caused by germs on fingers when dispensing the ointment. Therefore, the user can remove very hygienically the ointment from the jar.





Additionally, it is possible to open the jar by unscrewing the lid and removing compound remainders. The jar is resistant to hot-water baths and microwaves with temperatures maximum of 85°C / 185°F. Higher temperatures may alter the tightness of the jar and the sliding ability of the jar bottom might be negatively impacted. The jar material could become brittle at temperatures below 0°C / 32°F.

Jars are available in following sizes: 15 - 20/33 ml, 30/42 ml, 50/70 ml, 100/140 ml, 200/280 ml, 300/390 ml, 500/600 ml, 1000/1250 ml and 2000/2600 ml (rated volume/filling volume). The standard color of the jar housing is white and the lid red. The 300 ml, 500 ml, 1000 ml und 2000 ml jar come only with white lids.

! **Note**

- All jars come sealed in plastic packaging.
- Cleaning or disinfection prior usage could put the certified low microbiological contamination at risk.
- We would recommend storing the jar in its plastic packaging after opening for protection against possible dust contamination.
- A large applicator is standardly delivered with a 200 ml jar as pushing aid.

The jar sizes 300 to 2000 ml are particularly well suited as storage and transfer vessels for semisolids and other preparations. Since the contents dispensed using the movable jar bottom are always close to the lid, jars solve the problem of the unsightly contents in traditional porcelain vessels used previously.

Evaporation, formation of crust, contamination and oxidation processes can thereby be avoided to a great extent. Furthermore, the contents of the jar can be moved close to the lid after dispensing using the spindle or the AirDynamic.

As long as the housing of a 300 ml to 2000 ml jar is meant to remain in the pharmacy it can be cleaned in a dishwasher.



AirDynamic/Spindle

! **Note**

- Low microbiological contamination has to be ensured before reuse though.
- The movable bottom of the jar is not suitable for the dishwasher and the sealing lip of the jar lid may be destroyed after repeated mixing.
- The corresponding jar lids or jar bottoms can be ordered as spare parts in sets of five and used for the economical reuse of the body.

The jar is subject to periodic inspections in accordance to the guidelines of the Bundesapothekerkammer "Examination and Storage of primary packaging material". A certificate of analysis is issued after batch-defined examinations. After a visual receiving inspection the manufacturer's test certificate (certificate of analysis) is retained for the documentation of primary packing materials as stipulated. This certificate is affixed to the plastic packaging of the jar. If required, it can be removed and added to the stipulated documentation.

Certificate of analysis FagronLab™ jar

Jar label FagronLab™ jar

A detailed certificate is available for download at www.fagronlab.com/coa

A label is attached to each jar, which provides jar size, serial number (S/N), product number (PCN), date of packing, date of expiration and PPN. We recommend for a complete documentation to attach the jar label of the used jar onto the manufacturing record.

Notes on dispensing ointment

Each customer should be given specific instructions with an empty jar at how to use the jars. The use of the spindle should be explained for large jar, size 300 and 500 ml. Low viscosity ointments should be equipped with an applicator or a varionozzle to reduce the dispensed volume. Medium viscosity ointments can be easily extracted through the regular opening of the jar. Very pasty ointments (e.g. pasta zinc) may not necessarily be pressed through the regular opening, even by using a spindle.

In this case, the ointment can also be removed, similar to handling conventional jars with a regular lid, by removing the lid and with the help of a spatula. If the jar lid has been removed, the ointment should be pushed up close to the lid after each dispensing process. In larger jars by using the spindle or the AirDynamic.

The diameter of the dispensing nozzle allows simple dosing of the quantity of ointment to be applied using approximate values. The regular dispensing nozzle in the screw lid of each FagronLab™ jar has a diameter of 8 mm. The varionozzles or applicators reduce the diameter to 4, 2 or 1 mm. To ensure an exact dosage of highly active compounds, it is recommended to use the ExactDose Adapter. It is possible to extract an exact amount of 0.5 ml.

FagronLab™ varionozzles

The FagronLab™ varionozzles with inner diameters of 1, 2 or 4 mm can be pressed into the regular nozzle of any FagronLab™ jar. They reduce the opening size, making it possible to safely dose even low viscosity formulations. The viscosity of the finished product normally specifies the diameter of the varionozzles. The softly rounded surface allows ointment to be pleasantly spread directly onto skin.

The coloring was selected corresponding to the wavelength of light:

- 4 mm: red (long-wavelength light)
- 2 mm: yellow
- 1 mm: blue (short-wavelength light)



FagronLab™ applicators

The FagronLab™ applicators reduce the extracted quantity of low-viscosity formulations and are particularly helpful in cases where the ointment must be precisely applied.



FagronLab™ applicator short

The FagronLab™ applicator short with a diameter of 1 mm is obligatory for nose and ear ointments.

FagronLab™ applicator long

The FagronLab™ applicator long with a diameter of 2 mm allows formulations to be introduced into large orifices of the body or probes. In addition, the applicator long also comes inside each FagronLab™ 200 ml jar to help pushing up the bottom of this jar size in full.

FagronLab™ spindle

The FagronLab™ spindle serves as a dispensing system for FagronLab™ jar sizes 300 ml or 500 ml. Extract the spindle from the jar. Push carefully the bottom of the jar with a disinfected SMB (if not available, with a disinfected spatula) all the way down. Air can be diminished by placing the jar with slightly open lid loosely onto a spindle and pushing the bottom upwards. Before giving the jar to the customer, the safety adapter needs to be removed and the spindle must be screwed in the jar counter clockwise from the bottom until it locks into place. The spindle must be turned clockwise to extract the ointment. One turn dispenses approx. 20 ml of the contents of the jar.



Warning

- If the movable bottom is accidentally perforated or the spindle is permanently locked in the bottom of the jar, the jar may only serve as dispensing or storage vessel and can no longer be used for the mixing process.



FagronLab™ coupling

The FagronLab™ coupling connects two FagronLab™ jars by their screw threads of their dispensing openings and is very useful when preparing ointments in larger batches. Transferring a formulation from a larger jar into a smaller jar using the coupling will ensure hygiene from the mixing process to the end user. The 200 ml jar becomes a convenient transfer device to smaller jars when their jar bottoms are carefully pressed towards the work surface using an applicator, long screwed on a 30 ml jar. The jar coupling is available as FagronLab™ jar coupling 15 - 1000 ml and also as FagronLab™ jar coupling 2000 ml.

In addition to the coupling, required for transferring from a 300 ml or 500 ml jar into a smaller jar, both the spindle and the AirDynamic may also be used. Dispensing and transferring a formulation via the regular jar nozzle from a 1000 ml and 2000 ml jar is practically only possible using the AirDynamic.

We recommend transferring the formulation after mixing as soon as possible, since the formulation is still warm and less viscous.



FagronLab™ AirDynamic

The FagronLab™ AirDynamic optimizes batch preparation within the closed system:

- Contamination-free transfer
- Contamination-free storage

It is designed for FagronLab™ jar sizes from 300 to 2000 ml for hygienic transfer of the compound. The jar is attached to the base plate of the AirDynamic with the central hole at the bottom of the jar housing. By closing the easy-lock system on the side of the base plate, the jar is attached airtight.

By pressing the pump ball, with its valve screw closed, air is pumped into the lower chamber of the jar. The thus generated pressure pushes the movable bottom up. Thanks to the AirDynamic, even thick pastes can be dispensed via the small dispensing opening in the screw cap or transferred to small jars using the coupling. The material outlet velocity depends on viscosity which may be reduced through warming. The air pressure that has developed in the lower chamber of the jar can be relieved by opening the valve screw. This is mandatory after the transfer process using the coupling before the smaller jar is removed. Otherwise this may result in considerable contamination of the immediate environment, depending on the formulation viscosity.

FagronLab™ ExactDose adapter

The FagronLab™ ExactDose Adapter allows the exact dosage of 0.5 ml paste, gel, cream or ointment for topical or transdermal therapy. The adapter will be screwed onto the jar after the mixing process is finished. Insert the red set screw with a little pressure into the transparent part of the ExactDose Adapter. The coloured ball inside the ExactDose Adapter lays on its lowest position when the red set screw is horizontally positioned.

With pushing the jar bottom upwards the ExactDose chamber will be filled with the exact amount of compound and the coloured ball will be pushed up to its highest position. With a 180 degree turn of the set screw the coloured ball will be in the lowest position again, the compound will be extracted by pushing the jar bottom upwards and the chamber will be filled again with compound for the next dosage extraction.



4. Display handling

4.1 Initial operation



- The touch panel is on the front of the **EMP Standard**, with a minus button (left), the compounding button (middle) and a plus button (right)

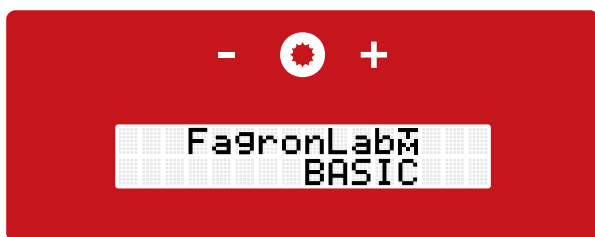

- After starting up the device with the power switch, located on the back, the display shows the device type "**FagronLab™ BASIC**"

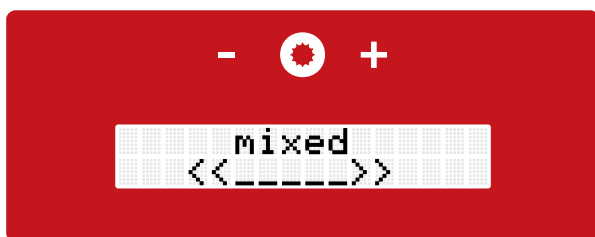

- Followed by the current number of preparations. After a few seconds it forwards automatically to the next screen.



- On initial operation the reference for the online registration at **www.fagronlab.com/re** will be displayed

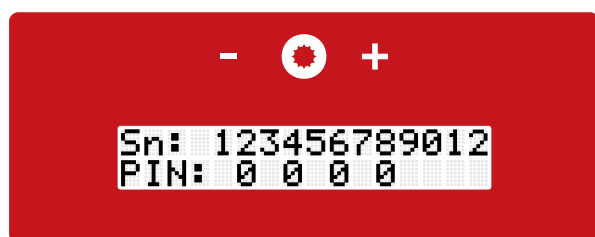

- Enter the 12 digit serial number online at **www.fagronlab.com/re** to register the new device. Then a four digit PIN number will be provided to activate the **EMP Basic**
- Enter the four digit PIN on the display of the **EMP Basic**

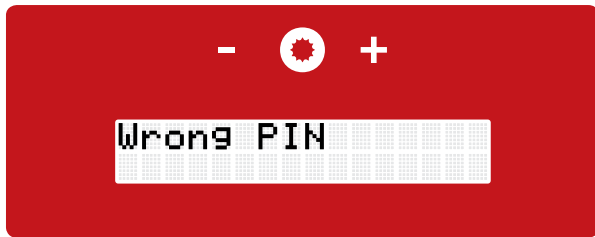

- The displayed numbers change with the plus and minus button. By pushing on the compounding button, it jumps to the next position. If a number is entered incorrectly, it is possible to navigate to the input position again
- By pressing the compounding button for three seconds the four digit PIN is confirmed
- If the PIN was not entered correctly the display will show **"Wrong PIN"**
- After pushing the compounding button the PIN can be entered.

Installation qualification (IQ)/Operation qualification (OQ)

- We recommend to perform a function test before using the device for the first time "Installation Qualification (IQ)".

IQ - Mode

- Fill a 50 ml FagronLab™ jar with following testing compound: Iron oxide (or a different colourful test substance) 0,01, Semi-solid foundation ad 50,00
- Insert the SMB into the test jar and close it
- Move the lift arm in its lowest position. To insert the mixing unit into the quick-lock coupling (review chapter 4 "quick-lock coupling"), it is recommended to use slight pressure from the top of the lift arm
- Press the compounding button for two seconds, the display will show **"IQ-Mode Start?"**
- Move the mixing unit up by hand and with pushing the compounding button the mixing process starts. The jar is moved by hand up and down in its available range, the complete compound needs to be interpenetrated from lid to bottom
- Every mixing speed level runs five seconds, to test intern if the actual speed of rotation equals the level of the given speed of rotation
- As soon as the EMP's display shows the free spin program
- Move the jar into its lowest possible position. After the process is finished, the mixing shaft automatically unlocks and the mixing unit in the lift arm can be moved to its lowest position for extracting
- By pushing the compounding button the start screen appears.



Not OK

- If the mixing speed level test determines discrepancies, the display shows **"please contact fs@fagronlab.com"**. Please contact the technical service per email with the serial number of the **EMP Basic**
- By pushing the compounding button the start screen appears.

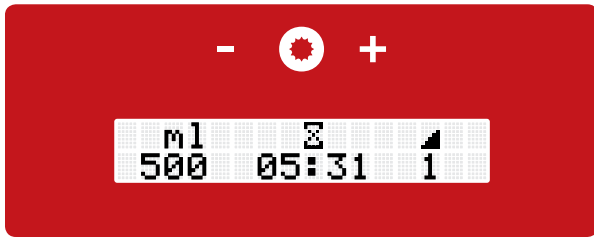

OK

- The device transfers to the start screen.

Skip the IQ - Mode

- Push the minus button for two seconds and the start screen will automatically appear

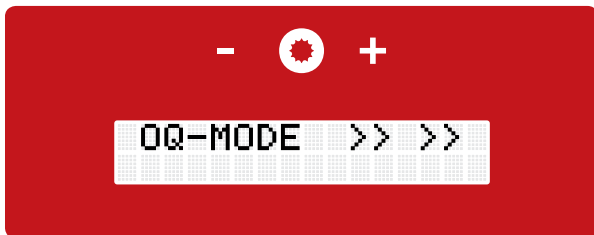

After 1000 preparations

- After 1000 preparations upon start the request to perform a functional test appears - Operation Qualification (OQ)
- We recommend to perform the functional test always after 1000 preparations to prove and record the proper functioning of the FagronLab™ device. This is the only way to ensure the expected mixing results are not affected by malfunctions caused by constantly usage of the FagronLab™ device. If a repeated OQ test is not wanted, it is possible to jump to the start display by pushing the minus button for two seconds
- If desired, the OQ functional test can be performed at any time by pushing the "+" and "-" button simultaneously for two seconds

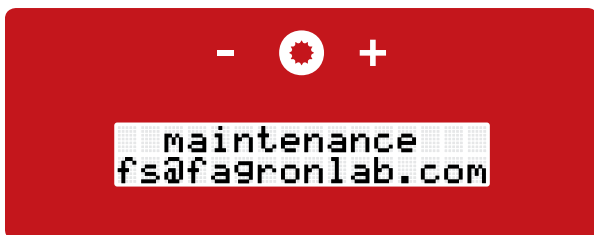

After 1500 preparations

- After 1500 preparations we recommend a maintenance performed by our technical service

4.2 Compounding with the EMP Basic



- The touch panel is on the front of the **EMP Basic**, with a minus button (left), the compounding button (middle) and a plus button (right).

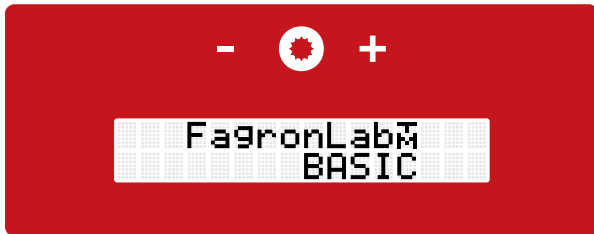

- After starting up the device with the power switch, located on the back, the display shows the device type "FagronLab™ BASIC"

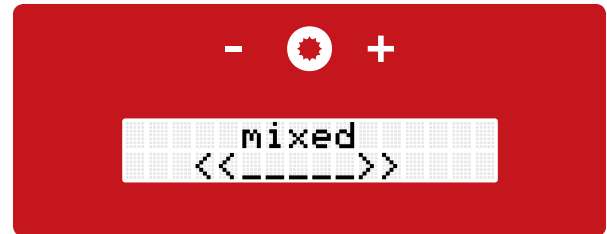

- Followed by the current number of preparations

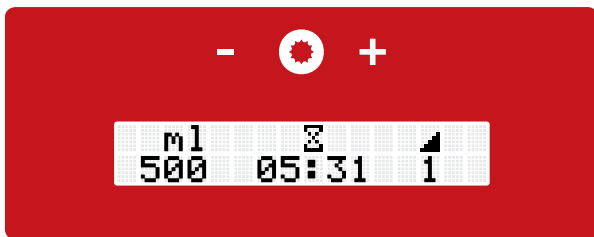

- After a few seconds, it forwards to the next screen
- The start display shows the jar size, mixing time and the mixing speed in levels.

- Both, the mixing parameters and the jar size, can be changed individually through pressing the plus and minus touch button. To switch between the operation settings push the compounding button. The changeable setting which will be modified with the plus and minus button flashes
- The time changes in five seconds steps by pressing the plus/minus button. If the plus/minus button is longer pressed down, the time setting changes will accelerate
- Depending which jar size will be used the recommended standard mixing speed level and the minimum mixing time will also automatically be changed. Due to high rotation the levels 8 and 9 are not suitable for manufacturing in the jar sizes 300 ml and 500 ml, therefore, they are disabled for these quantities

- The lift arm is in its lowest position. To insert the mixing unit into the quick-lock coupling (review chapter 4 "Quick-lock coupling"), it is recommended to use slight pressure from the top of the lift arm
- Press the compounding button for two seconds, the display shows "Start?". Move the mixing unit up by hand and with pushing the compounding button the mixing process starts. The jar is moved by hand up and down in its available range, the complete compound needs to be interpenetrated from lid to bottom.

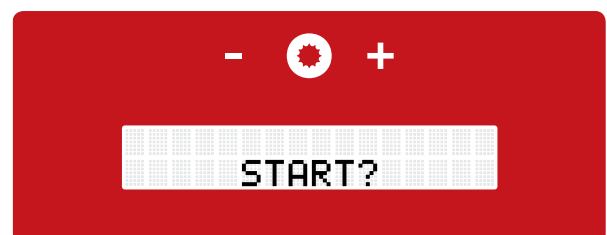
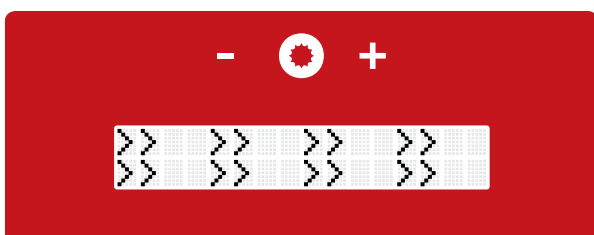

- During the mixing process it is possible to change the mixing time and mixing speed
- The changeable parameter flashes, to switch between the parameters push the compounding button
- After the mixing process is finished the display "**Free spin program**" appears. Move the jar as far as possible down
- Pressing the compounding button for two seconds confirms the "**Y**". The free spin program starts, which removes mostly the compound from the mixing blade
- Selecting "**N**" aborts the free spin program
- When the free spin program is finished, the mixing shaft automatically unlocks and move the lift arm into its lowest position to remove the mixing unit
- With every finished mixing process, the **EMP basic** will automatically issue an identification number. The identification number will help with easier documentation and exact reproduction of the mixing process. We recommend to record the ID number on the manufacture protocol (chapter 6 "Identification number ID").

4.3 Aborting the mixing process

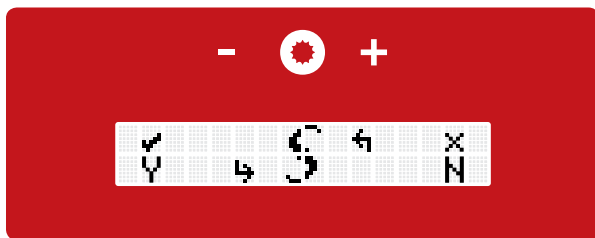

- To abort the mixing process push the compounding button for two seconds
- The device asks if the free spin program should be initiated.
- By confirming "**✓/Y**" the free spinning starts. If selected "**X/N**" the program aborts. In both cases no ID-number is issued. To select the option push the compounding button. To confirm the selection push the compounding button longer
- After pushing the compounding button the start display appears to select new mixing parameters for a following compound.

5. Compounding guidelines for the technology

5.1 Preparing the FagronLab™ mixing unit

The FagronLab™ mixing unit consists of a Fagron-Lab™ jar, a FagronLab™ stirrer and the components of the formulation to be mixed.

First, the jar cap (small red screw cap) of the jar and then the jar lid (large red, white or coloured screw cap) must be unscrewed from the jar.

Second, the stirrer is inserted into the jar housing and used to slide the jar bottom straight down. The jar lid is then slid onto the stirrer standing in the jar housing and pressed down firmly using both thumbs. Ensure that the sealing lip of the jar lid opening is not damaged by the bayonet noses, because the ointment may otherwise rise up the stirring shaft during the mixing process.

Third, the stirrer is carefully removed from the jar and the jar lid will be moved all the way in the direction of the blade. Both parts, i. e. the stirrer and the jar lid are put down or possibly tare on the scale together with the jar.

After weighing out the formulation components into the jar, the lid including the stirrer has to be screwed on. Afterwards move the lid with a slight twist, about half a centimeter, to open it a tad. By pushing the bottom up with the thumb or for large jars, with help from an applicator, the spindle or AirDynamic the air will escape between the jar lid and the jar housing. This process is called **air diminution**.

Air diminution will prevent ointment exudation at the sealing zones of the jar through reduction of any overpressure that may have developed. The mixing result is also optimized since there is no trapped air. Then the mixing unit should be closed by tightly screwing the jar lid down.

5.2 Weighed portion of the formulation

Generally, oily, greasy, aqueous and pulverized components can be weighed out into the jar all at the same time. However, it is advantageous to consider certain general procedures to optimize the mixing results. Generally, know-how gained from the traditional preparation of ointments is very helpful when using the mixing device. As already mentioned at the beginning of the operating manual, true to the motto: **learning by doing**.

The given mixing parameters are general procedures used to produce the routine standard formulations in pharmaceutical preparation of compounds. In the following, these standard formulations will be defined and the recommended procedure on weighing described.

This will produce a code of practice for orientation. This does not exclude other possible methods for optimisation.

For mixtures with high liquid content, ensure that the ointment foundation on the jar bottom is first carefully placed around the sealing lip. This enhances the leak tightness of the jar.

5.3 The mixing process

The **EMP Basic** is the result of continuous improvements. Featuring a guided lift arm, programmable mixing time and mixing speed, the **EMP Basic** is not just standard for the pharmacy. The **EMP Basic** is equipped with a quiet and constantly usable permanent motor and is the ointment mixing device for individual and bulk compounding from 15 ml up to 500 ml. To prepare compounds homogeneously, the **EMP Basic** works in a rotation range from 300 up to 2400 rpm.

For every jar size different mixing parameters are already set in the **EMP Basic**. These serve as recommended minimum mixing time and minimum mixing speed. They have to be adjusted accordingly to each type of formulation. Due to high rotation speed the levels 8 and 9 are not suitable for manufacturing in the jar sizes 300 ml and 500 ml, they are disabled in the mixing time selection.

The mixing time can be set from 5 seconds to 99:30 minutes and the mixing motor in 10 levels from "0" to "9". The exact rotation speed for each level are provided by the following table chart. The rotation speed is measured in the unit rpm.

Level	Rotation speed (rpm)
0	300
1	600
2	800
3	1000
4	1200
5	1400
6	1650
7	1900
8	2150
9	2400

Tab: Value chart rotation speed

After selecting jar size, mixing speed and time, move the lift arm into the lowest position. The new FagronLab™ jar can be easily loaded into the lift arm due to the quick-lock coupling.

Quick-lock coupling

Hold the FagronLab™ logo, on top of the jar, to the front. Load the stirring shaft directly from the front into the lift arm. Push up the mixing unit, at the same time apply slight pressure from the top to the lift arm and with a slight turn counterclockwise (about a quarter turn) fix the mixing unit into the lift arm.

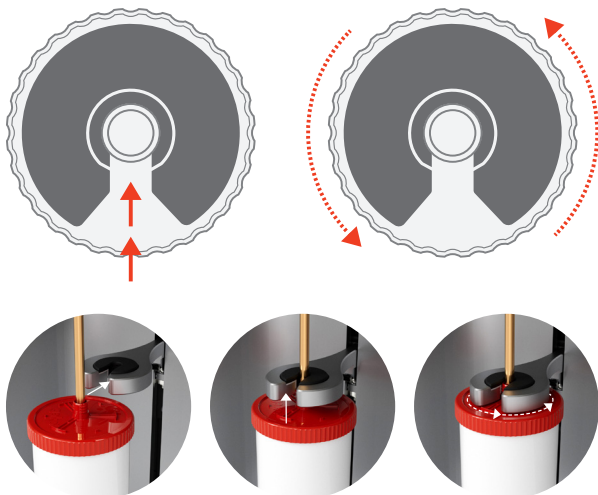

Move the mixing unit so far up that the bayonet noses are inserted into the device top. After pushing the confirm button the mixing process will start. The mixing unit has to be moved evenly up and down in its available range (lid-bottom).

The lift guidance will support the process enormously. After the mixing process is finished the free spin program will be initiated. The display will show:

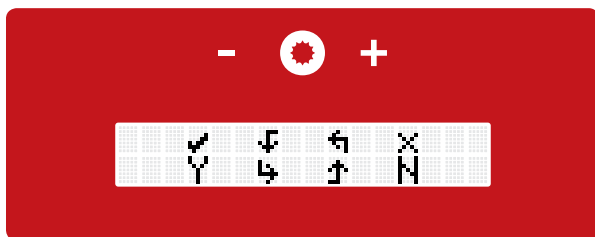

Move the lift arm all the way down, until the stirrer will touch the FagronLab™ jar lid. After confirming with the compounding button the mixing motor will accelerate to level "9". The MB will be mostly clean, the mixing process is finished and move the lift arm into its lowest position for an easy extraction of the mixing unit.

With every finished mixing process the **EMP Basic** will automatically issue an identification number (ID). The identification number will simplify documentation and exact reproduction of the mixing process and will be shown on the display after every mixing process.

5.4 Mixing parameters

Pre-grinding

The pre-grinding process serves to wetten solids in the preparation of suspension with an active substance content < 2%, allowing a homogeneous distribution of active substances in an ointment foundation.

As an example, the incorporation of corticoids, antibiotics, fungicides or hormones in an ointment foundation. In order to ensure a homogenous distribution, we recommend using the standard mixing blade.

First, load approximately 30% of the foundation ground-covering in the jar and cover the micronized active substances with foundation. The active substances have to be covered in the foundation in order to avoid powder residue sticking on the blade.

The jar bottom should be pushed up as far as possible to prevent incorporating air.

Please inspect the preparation for agglomerates or qualitative abnormalities after the pre-grinding process is completed. If required, the pre-grinding process may be repeated.

Level 4 (1200 rpm)		
Jar size	Time (min.)	Stirrer
15 - 30 ml	2:30	SMB
50 - 100 ml	3:30	SMB
200 ml	5:00	SMB
300 - 500 ml	10:00	SMB

Tab: Mixing parameter pre-grinding

Further processing of the compound should be prepared by using the parameters "**Suspension < 2%**".

Suspension < 2%

After finalizing the pre-grinding process both the remaining foundation and all active substances will be weighed in. To incorporate air as little as possible push the movable jar bottom up until resistance is felt.

Level 7 (1900 rpm)		
Jar size	Time (min.)	Stirrer
15 - 30 ml	1:30	SMB
50 - 100 ml	2:00	SMB
200 ml	3:30	SMB
300 - 500 ml	4:40	SMB

Tab: Mixing parameter suspension < 2%

Suspension > 2%

With the mixing parameters “**Suspension > 2%**” solid substances of more than 2% can be incorporated into foundation.

As an example, the incorporation of zinc oxide, salicylic acid or bismuth gallate in foundation. To ensure a homogeneous distribution we recommend using the standard mixing blade.

For suspensions with ingredient content above 2% pre-grinding process is not required.

In preparation, add 50% of the required foundation ground-covering into the jar and the micronized solids to the middle. Add the remainder of the base on top of the ingredients in order to avoid remaining powder sticking to the blades.

The jar bottom should be pushed up as far as possible to prevent incorporating air.

Compounds with a higher content of solids, e.g. pastes, warming of the compound during the mixing process may occur. This temperature rise may be reduced applying cooled foundation or using a cooling cuff.

Level 8 (2150 rpm)		
Jar size	Time (min.)	Stirrer
15 - 30 ml	3:00	SMB
50 - 100 ml	3:50	SMB
200 ml	6:45	SMB
300 - 500 ml	9:30	SMB

Tab: Mixing parameter suspension > 2%

Emulsion (solution ointment)

With the mixing parameters “**Emulsion**” liquid components can be incorporated into hydrophilic foundations at room temperature.

As an example, the preparation of aqueous hydrophilic ointment, aqueous lanolin alcohol ointment or eucerin c. aqua aa. To ensure a homogenous distribution we recommend applying disp. blades for jar sizes up to 200 ml and the standard mixing blades for larger batches.

First, weigh out the entire amount of required foundation ground-covering inside the jar.

Then add the required amount of liquid or solution by room temperature. The jar bottom should be pushed up as far as possible to prevent incorporating air.

In some cases emulsifying refrigerated foundations can cause difficulties. In this case the process of emulsification can be accelerated by adding the required liquid warmed.

Level 8 (2100 rpm)		
Jar size	Time (min.)	Stirrer
15 - 30 ml	2:00	Disp. Blade
50 - 100 ml	2:20	Disp. Blade
200 ml	4:10	Disp. Blade
300 - 500 ml	5:30	SMB

Tab: Mixing parameter Emulsion

Emulsion+

With the mixing parameters “**Emulsion+**” liquid components can be incorporated into a melted foundation and cooling down parameters. As an example, the preparation containing emulsific. aquosa, lanette or cera.

To ensure a homogenous distribution we recommend applying disp. blades for jar sizes up to 200 ml and the standard mixing blades for larger batches. The jar is heat resistant up to 85°C/185°F and can be used in a hot-water bath or microwave. The melting components can be melted directly in the jar.

If there is no water in the formulation, the components can be melted directly in the jar on a hot-water bath. Formulation containing an aqueous phase can be melted in a hot-water bath or the microwave, leave the regular nozzle open and set the microwave to a low power setting. The temperature control with a thermometer should take place in short intervals to make sure the compound is not overheating. To support the cool down process with the **EMP Basic** a cooling cuff can be used around the jar and the mixing process for larger jar sizes can be repeated.

Step 1: combining phase - Level 1 (600 rpm)		
Jar size	Time (min.)	Stirrer
15 - 30 ml	0:30	Disp. Blade
50 - 100 ml	0:30	Disp. Blade
200 ml	0:30	Disp. Blade
300 - 500 ml	1:00	SMB

Step 2: emulsions phase - Level 7 (1900 rpm)	
Jar size	Time (min.)
15 - 30 ml	1:00
50 - 100 ml	1:00
200 ml	1:00
300 - 500 ml	2:00

Step 3: cool down phase - Level 1 (600 rpm)	
Jar size	Time (min.)
15 - 30 ml	10:00
50 - 100 ml	10:00
200 ml	10:00
300 - 500 ml	10:00

Tab: Mixing parameter Emulsion +

Use Cool down phase and emulsions phase alternativ until compound reaches room temperature.

Gel

With the mixing parameter “Gel” gelling agents can be incorporated into fluids or semi-solid foundation.

As an example, the preparation of ultrasonic contact gel, hydroxypropyl cellulose 400. Also incorporation gelling agents like bentonite or Aerosil into a semi-solid foundation.

To ensure a homogenous distribution we recommend applying disp. blades for jar sizes up to 200 ml and the standard mixing blades for larger batches. The fluid component will be weighed out first into the FagronLab™ jar. Soluble active substances can be administered directly into the jar and dissolved. The gelling agent will be dispersed on top of the liquid component.

If the swelling agent will be incorporated into a semi-solid foundation, the gelling agent can be covered between two foundation layers. This will obtain a faster dispersion of the gelling agent into the foundation.

Step 1: moistening - Level 8 (2150 rpm)		
Jar size	Time (min.)	Stirrer
15 - 30 ml	0:30	Disp. Blade
50 - 100 ml	0:30	Disp. Blade
200 ml	0:30	Disp. Blade
300 - 500 ml	1:00	SMB

Step 2: swelling phase - Level 1 (600 rpm)	
Jar size	Time (min.)
15 - 30 ml	8:30
50 - 100 ml	9:30
200 ml	10:00
300 - 500 ml	10:00

Tab: Mixing parameter Gel

Alternate the mixing steps at least twice or until a homogeneous gel structure is reached.

Suppositories

With the mixing parameters “Suppositories”, suppository compounds mixtures can be dispersed.

The suppository foundation can be warmed in a water bath directly in a transparent jar and afterwards stirred with the FagronLab™ to the soft melting point. An applicator long aids in the precise filling of the suppository mould. For a batch approximately 5% to 10% added allowance is recommended.

Soft in soft

With the mixing parameters “Soft in Soft” semi-solid substances from low-viscous to pasty can be mixed together. As an example, combining two foundations.

To ensure a homogeneity we recommend applying disp. blades for low-viscous and the standard mixing blades for high-viscous foundations.

Level 7 (1900 rpm)		
Jar size	Time (min.)	Stirrer
15 - 30 ml	1:40	Disp. Blade
50 - 100 ml	2:10	Disp. Blade
200 ml	4:10	Disp. Blade
300 - 500 ml	5:10	SMB

Tab: Mixing parameter soft in soft

Specialties

With the mixing parameters “Specialties” surface-active or sensitive active substances or force sensitive foundations can be processed. As an example, metronidazole, chlorhexidine gluconate, Linola®.

Therefore with suspension ointments < 2% first use the “Pre-grinding” parameters and for the main mixing process the mixing parameters “Specialties”.

Level 4 (1200 rpm)		
Jar size	Time (min.)	Stirrer
15 - 30 ml	5:00	Disp. Blade
50 - 100 ml	7:30	Disp. Blade
200 ml	12:55	Disp. Blade
300 - 500 ml	17:00	SMB

Tab: Mixing parameter specialties

5.5 Requirements for the components of a formulation

Powder

Generally, powders should be used as microfine and micronized substances. In order to ensure better wetting of powders in aqueous compounds, micronized substances should be added after any liquid components or covered with foundation.

For a solids content less than 2%, we recommend applying the pre-grinding process together with approx. 30% of the ointment foundation (review pre-grinding). The jar bottom should be pushed up as far as possible to prevent incorporating air.

Please inspect the preparation for agglomerates or qualitative abnormalities after the pre-grinding process is completed. If required, the pre-grinding process may be repeated.

Crystalline active substances

We recommend pulverizing active crystalline ingredients in a mortar prior adding into the jar to avoid complex post processing (e.g. ointment mill). Should a solvent for the active crystalline component be part of the formulation, the ingredient may then also be dissolved in the jar, for example urea with water.

Then the remaining formulation component/s can be added. If the solvent is in sufficient amounts a component of the ointment foundation, the crystalline substance may dissolve during the mixing process.

Components to be melt

Components that have been weighed out to fuse may be placed inside a jar, douse with heated aqueous or oily phases of the formulation components (< 85°C / 185°F) to melt the content in full.

In case this process does not sufficiently melt all the components, the formulation inside the jar might be heated in a warm water bath (< 85°C / 185°F) or carefully observed in a microwave oven. In order to avoid overpressure in the jar remove the red cap of the jar lid.

Formulations without water containing components may be melted directly inside the jar by placing the jar in a warm water bath.

Please be aware that stirrers must not go into the microwave oven! Furthermore, due to irregular mixing of oily and water phases, reaching the melting point might happen with a delay, since only aqueous phases will be heated by microwaves.

Please consider also the operation manual of the used microwave oven! An excessive temperature rise for both, jar and its content, must be avoided all the time!

The cooling time and the cooling interval can be decreased by using a refrigerator or a cooling cuff. The stirrer should remain in the jar during the cooling phase.

Thermolabile substances

Active substances or components with thermolabile characteristics should be processed with caution. To protect the substances, we recommend a maximum speed of 1200 rpm (level 4). To control the frictional heat, a cooling cuff can be used or a cool down interval in a refrigerator if required.

5.6 After the mixing process is complete

After finishing the mixing process the mixing unit will be released and can be removed from the lift arm. Unscrew the jar from the lift arm, this will only require a quarter turn clockwise.

In the next step, the jar lid should be opened and the stirrer removed. Since this is also an opportunity, execute an organoleptic quality check, the jar lid should also be opened after mixing when using the Disp. Blade.

Practice has proven that if the surface of the compound looks smooth and consistent, complying with the minimum defined mixing time, homogeneity inside the jar also can be expected for the entire product.

Afterwards slide the stirrer out of the jar lid. The ointment on the stirrer can be cleaned off into the jar by using a spatula. When using the Disp. Blade, the stirrer can be removed from the jar and disposed, or left inside the jar.

Leaving the blade inside the jar will have no effect on dispensing the ointment through the jar lid. Removal of the disposable mixing blade is recommended, particularly when giving the ointment to elderly clients, since it might otherwise cause confusion if the ointment is traditionally dispensed.

The jar lid is screwed back onto the jar body and equipped with a varionozzle as needed. Then the little cap or a applicator will be loosely screwed on.

Move the finished compound close to the lid to prevent a "squirting out" of the ointment when first dispensed. A large applicator is standardly delivered with a 200 ml jar as pushing aid. Jars 300 ml up to 2000 ml use a spindle or the AirDynamic. The little cap or the applicator may now be fasten in place.

A label may be attached on the jar prior forwarding to the client, preferably together with a short illustration of how to use and apply the FagronLab™ dispensing system.

After completion of every single process, the **EMP Basic** issues automatically an identification number (ID). The display shows the ID and it conducts an easier documentation and an exact reproduction of the mixing process.

The FagronLab™ mixing parameters are an assistance in the right handling of the technology. The manufacturing with the FagronLab™ devices lies in the responsibility of the pharmaceutical personal.

6. General notes on the FagronLab™ mixing system

6.1 Identification number ID

The 13-digit identification number used to unmistakably mark preparations has the following structure:



The first number of the identification number provides information about the jar size, whereby each jar size is assigned to one of the following numbers:

FagronLab™ jar	Jar size in ml
1	15
2	20
3	30
4	50
5	100
6	200
7	300
8	500

Tab: Number/jar size correlation

As from the second position the mixing time and the rotation speed in 6 mixing stages are represented. The time specification is represented with large- and lowercase letters, in which each letter correlates to a defined time value:

Letter	mm:ss	Letter	mm:ss
A	0:05	a	2:20
B	0:10	b	2:30
C	0:15	c	2:40
D	0:20	d	2:50
E	0:25	e	3:00
F	0:30	f	3:10
G	0:35	g	3:20
H	0:40	h	3:30
I	0:45	i	3:40
J	0:50	j	3:50
K	0:55	k	4:00
L	1:00	l	4:20
M	1:05	m	4:40
N	1:10	n	5:00
O	1:15	o	5:20
P	1:20	p	5:40
Q	1:25	q	6:00
R	1:30	r	6:25
S	1:35	s	6:50
T	1:40	t	7:15
U	1:45	u	7:40
V	1:50	v	8:05
W	1:55	w	8:30
X	2:00	x	9:00
Y	2:05	y	9:30
Z	2:10	z	10:00

Tab: Letter/time correlation

The input of the rpm is assigned to the numbers 0 - 9, in which each number correlates to a defined rpm value:

Level	Rotation speed (rpm)
0	300
1	600
2	800
3	1000
4	1200
5	1400
6	1650
7	1900
8	2150
9	2400

Tab: Number/rpm correlation

6.2 Error codes

Error	Cause	Troubleshooting
F1	The stirrer lock detached during the mixing process	Restart the mixing process.

Tab: Error codes

6.3 Operation errors

FagronLab™ stirrer

Error	Cause	Troubleshooting
1	The stirrer used is not compatible with the EMP Basic.	The stirrer used is not an original FagronLab™ stirrer. The EMP Basic has only been tested, centered and aligned with original FagronLab™ stirrers. All stirrers delivered after the year 1996 are compatible with the EMP Basic.
2	There are problems while coupling the stirrer with the EMP Basic.	The FagronLab™ stirrer is bent or damaged! Replace it with an intact stirrer! The FagronLab™ stirrer is not straight in the FagronLab™ jar. Straighten the stirrer.
3	The FagronLab™ stirrer does not penetrate completely in the mixture, since the formula is to pasty, firm, or in powder form.	To ensure the complete mixing of the recipe, you can for example, warm cold recipe substances in room temperature.

Tab: Operation errors/stirrer

FagronLab™ Jar

Error	Cause	Troubleshooting
1	The jar connected to the EMP Basic is not a FagronLab™ jar.	The jar has to be substituted for a FagronLab™ jar.
2	The FagronLab™ jar lid was screwed alsant onto the jar and the stirrerconts on insertion.	Open the jar and screw the lid on correctly.
3	At first time extraction the ointment leaks out in a gush.	Diminish air before the first time extraction.
4	Liquid leaks out on the bottom of the jar.	The bottom of the jar was not completely covered with foundation all the way to the rim of the jar bottom. Ensure to cover the sealing lip of the bottom with foundation. After using the jar in a water bath, water accumulated in the cavity on the bottom side of the jar. The water cannot penetrate into the jar itself through the sealing lip, remove the excess water with a paper towel.
5	The jar does not attach into the lift arm.	The jar is not an original FagronLab™ jar. Always use an original FagronLab™ jar. Please observe the correct handling of the quick-lock coupling (see description on next page)

Tab: Operation errors/jar



- Hold the FagronLab™ logo, on top of the jar, to the front
- Load the stirring shaft directly from the front into the lift arm.
- Push the mixing unit up and with a slight turn counterclockwise (about a quarter turn) fix the mixing unit into the lift arm.

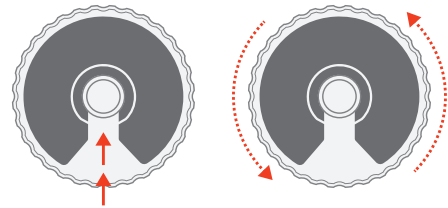

Common errors

Error	Cause	Troubleshooting
1	The compound rises up the stirrer shaft.	The sealing lip from the lid is damaged. Replace the lid with an intact one.
		The air was not diminished before the mixing process. Repeat the compounding and diminish the air correctly before the mixing process.
		The foundation is known to rise (eg. Linola®, hydrophilic cream). Refrigerate the foundation prior the compounding and diminish the air correctly.
2	A suspension ointment is not homogeneous mixed.	For the mixing process a Disp. Blade was used not the SMB. Always use the SMB for suspension ointments. The wide blades of the stirrer together with the inner wall of the jar breaks down agglomerate and the active substance dispenses homogenic.
3	The finished compound is at the organoleptic final quality control inhomogeneous.	Instead of micronized solid substances crystalline substances are used. To ensure homogeneity use the ointment mill or micronized solid substances.

Tab: Operation errors/common errors



Note

- Please contact customer service for any malfunctions cannot be remedied using this information.

6.4 Cleaning the EMP Basic

- Always unplug the **EMP Basic** from the wall outlet before performing a cleaning.
- Do not use aggressive cleaning agents or abrasive cleaners.
- For cleaning, we recommend daily wiping the surface with a damp cloth with mild detergent and immediately drying it with a dry cloth. For disinfecting, the display can be lightly sprayed and wiped with isopropanol 70%.
- Make sure that no liquids enter the device. If liquids enter the interior of the **EMP Basic**, keep the device turned off and inform customer service. An unauthorized opening of the **EMP Basic** device is not permitted.

7. Service and warranty

7.1 Notes on malfunctions

If the FagronLab™ device does not work, it may be due to a small problem that can be simply corrected. Before taking the unit for repair, please follow the instructions below:

- If the FagronLab™ device can not be switched on, please check to ensure that there is electricity available and that the plug of the power cord has been correctly connected to the device and the socket
- In any case of problems or damage of the device, please also mind the manufacturer's notes on the machines' metal foot.

7.2 Notes on safety

- FagronLab™ devices must only be connected to grounding type receptacles with 230V / 50Hz (cps); 120 V / 60Hz (cps) or rated country specific voltage installed according to the regulations of DIN VDE 0100
- FagronLab™ devices have been designed for operation under normal room atmospheric conditions. Recommended values: Ambient temperature between 15 - 30°C / 59 - 86°F and relative air humidity less than 80%
- The device should be allowed to acclimatize for approx. 30 minutes at initial commissioning and/or after extended storage time in cold rooms
- The **EMP Basic** should be placed to ensure easy access to the power switch and power cable also to avoid use by unauthorized persons
- Do not immerse FagronLab™ devices in water
- Electronic parts should just be dis- and assembled by a certified service partner
- Only operate the FagronLab™ stirrer inside a closed FagronLab™ jar
- Do not touch rotating parts
- Keep long hair away from rotating parts
- During the automated lifting of the **EMP Pro**: always keep long hair, body parts or objects away from the lifting mechanism. Immediately turn off the power switch in case of an emergency or pull the power plug
- Using the FagronLab™ devices not according to these operating instructions or with line products that the manufacturer did not deliver or recommend may impair safety
- FagronLab™ devices have not been designed for operation under hazardous conditions. Heed the relevant safety regulations when handling hazardous substances (e.g. combustible liquids such as alcohol or similar substances)
- FagronLab™ devices correspond to the safety standards for laboratory equipment. They have to be positioned to prevent any interference or use by unauthorized persons
- The device must not be disposed of in ordinary domestic waste. Please deliver the device to the available collecting and recycling systems at the end of its life cycle.

7.3 Technical data of the EMP Basic

FagronLab™ jar	Jar size in ml
Electrical requirement	100 - 115 V / 220 - 240 V
Total power consumption	80 W
Power consumption (mixing motor)	80 W
Operating mode	continuous operation S1
Safety class	I
Type of protection	IP 20
Connection	1x RS232 port
Rotational speed controller	in 10 steps electronic controlled
Timer	continuous electronically
FagronLab™ jar sizes	15-20 ml - 500 ml
Weight	22 lbs/10 kg
Dimensions (LxWxH)	255x211x512
Testing certifications	CE

8. Manufacturing and Customer Service

The **EMP Basic** is certified:
Certificate of Conformity



The certificate is available at the license holder, Gako Konietzko GmbH, D-96049 Bamberg.
The license manufacturer of FagronLab™ products, the Gako International GmbH, D-96110 Schesslitz,
is DIN EN ISO 9001:2015 certified.

For inquiries regarding FagronLab™ technology products please refer to your local
Fagron company or official dealer.

Customer Service

With all inquiries about technical data, service, warranty,
customer service or replacement parts contact the
customer service of your local Fagron company or official dealer.

8.1 Installation qualification (IQ)

Company (Pharmacy)

Device identification

Serial number (SN):

Date of purchase:

Assessment	OK	not OK
Examination of readability of the labels on the device		

Considering appropriate installation conditions

Assessment	OK	not OK
Stable, flat surface, observe product weight		
Suitable space for the device and unobstructed access to the power cord and power switch		
No direct air flow (windows, heating, fans, air conditions)		
No direct sunlight		
No extreme humidity or temperature fluctuations		
Clean, dry, dust-free		
Correctly installed, earthed socket with 220 Vor country-specific nominal voltage and required grid frequency		
Before initial operation acclimate the device for 30 minutes at room temperature		
Excludes device handling by unauthorized persons		
Observe the operation manual and manufacturer's recommendations		

Testing initial operation

Assessment	OK	not OK
Place the device securely		
Establish the power supply, connect the device with the power outlet		
Turn on the FagronLab™ EMP device with the power switch		
The display shows the device type "FagronLab™ EMP"		
The display shows the number of current number of preparations "mixed <<----->>"		
The display shows "IQ - Mode >> >>"		
Attach the test mixing unit (review chapter 4) into the quick-lock coupling (review chapter 5)		
The compounding button starts the IQ-Mode		
The display shows all the levels during IQ-Mode		
The display shows IQ-Mode "OK"		
Remove the test mixing unit (review chapter 5)		
Jump between configuration options with the Compounding button		
Use the +/- buttons to decrease and increase the jar size		
With changing the jar size mixing time and mixing parameters are adjusting		
Use the +/- buttons to decrease and increase the mixing time		
Use the +/- buttons to change the mixing level from 0 to 9		
Observe the operation manual		

	Date	Signature
Performance of the test		
Approval by pharmacist		

8.2 Operation qualification (OQ)

Company (Pharmacy)

Device identification

Serial number (SN):

Date of purchase:

Assessment	OK	not OK
Examination of readability of the labels on the device		

Functional testing

Assessment	OK	not OK
The device is securely placed		
Power is supplied		
Turn on the FagronLab™ EMP device with the power switch		
The display shows the device type "FagronLab™ EMP"		
The display shows the number of current number of preparations "mixed <<---->>"		
The display shows "OQ - Mode >> >>"		
Attach the test mixing unit (review chapter 4) into the quick-lock coupling (review chapter 5)		
The compounding button starts the OQ-Mode		
The display shows all the levels during OQ-Mode		
The display shows OQ-Mode "OK"		
Remove the test mixing unit (review chapter 5)		
Observe the operation manual		

	Date	Signature
Performance of the test		
Approval by pharmacist		

Together
we create the future
of personalizing medicine.



Fagron BV
Fascinatio Boulevard 350
3065 WB Rotterdam
The Netherlands

T +31 88 33 11 288
F +31 88 33 11 210
www.fagronlab.com

 **Fagron**
lab